

WARNING: Read the ENTIRE instruction manual to become familiar with the device and its features before operating. Failure to operate the product correctly and safely may result in damage to the product, personal property and cause serious injury.

This product must be operated with caution, common sense and in harmony with any regulations in place. Usage requires mechanical and electrical ability. Failure to operate this Product in a safe and responsible manner could result in injury or damage to the product or other property. This product is not intended for use by children. Do not attempt disassembly, use with incompatible components or augment product in any way without given approval by the manufacturer. This manual contains instructions for safety, operation and maintenance. It is essential to read and follow all the instructions and warnings in the manual, prior to assembly, setup or use, in order to operate correctly and avoid damage or serious injury.

Age Recommendation: Not for children

Only to be used by trained adult persons.

Throughout the literature the following terms will be used to indicate various levels of potential harm when operating this device.

NOTICE : Procedures which, if not properly followed, create a possibility of physical property damage AND a little or no possibility of injury.

CAUTION : Procedures which, if not properly followed as described in this manual, create the probability of physical property damage AND a possibility of serious injury.

WARNING: Procedures which, if not properly followed, create the probability of property damage, collateral damage, and serious injury OR create a high probability of superficial injury.

WARNING: This device may not be used for applications requiring fulfillment of special safety standards. Among others this includes: Certain vehicles, aircrafts, certain machines and operation in safety critical environments like medical, nuclear and military! Before us this device may need to undergo additional testing to standards in place.

Integrating your VESC motor controller into an electrical System:

Your VESC controller is designed to be integrated into a battery powered electrical system only! The sketch above shows how to integrate your VESC controller into such a system. Minimum requirements for safe operation:

1. Integration of a **safety power cut-off**.
2. The integration of a **FUSE**, rated in accordance of your electrical system (weakest part of the system).
3. Use of **anti spark connectors and switches (pre-charge)**. Use of a **compatible input device** (legal to operate, free of interference, reliable).
Shown: PPM (Pulse Position Modulated) 2.4GHz receiver
4. Using safe setting for the operation in accordance with your electrical system and components involved.
5. Use a **Battery Management System (BMS)** if the motor is used for regenerative braking or as a generator.
6. Follow general safety measures for your device/system, as legally required.
7. Keep device dry at all times. House device against water ingress according to required IP rating.

Safe Settings and Operation for Motor and Battery Settings (Motor Settings Panel, General):

WARNING: This device is intended to be used with the original Open Source Software *VESC-Tool*. Usage of other software than stated voids warranty and statement of conformance! This is a guide to set up your device within the measures of safe operation. Stay safe! To prevent injuries, operate your motor without attached propellers, wheels and/or moving mechanical parts when doing/changing your setup. Stay clear of any moving parts! Motor will spin up during setup! If you are not an expert, please use the Wizards for Setup! Additionally apply safe settings for the temperature cutoffs to prevent over heating.

- **BLDC Mode:** Block Commutation (Trapezoidal), more noise, less efficient, sometimes lesser likelihood to experience problems.
- **FOC Mode:** Sinosoidal Commutation (Sine Wave), free of noise / vibrations, more efficient, more complex.
- **Sensors:** Does your motor/ setup incorporates motor sensors? Do you want to use them? (Hall, ABI, AS 5047P Sensors)
Did you check and adjust the sensor voltage (3.3 / 5V)?
- **Battery Cutoff Start:** System decreases power usage when voltage drops below defined value, e.g. 3.4V per cell for LiPo (battery protection/health).
- **Battery Cutoff End:** System stops motor when voltage drops below defined value, e.g. 3.1V per cell for LiPo (battery protection/health).
- **Motor Current Max:** Defines maximum allowed Amp draw for the Motor. Can your motor cope with your setting? Does anything get hot during operation?
- **Motor Current Max Brake:** Defines maximum allowed current being generated by the motor (regenerative braking).
Warning: Wrong settings may overstress your motor/generator and/or battery! Read the warnings below!
- **Absolute Maximum Current:** Max. Amp flow allowed in your electrical system (peak).
- **Battery Current Max:** Max. allowed continuous current drain according to batteries technical data sheet. Read warning below!
- **Battery Current Max Regen:** Max. current fed back into your battery pack. Check batteries data sheet to prevent dangers or battery damage. Read warnings below!
- **MOSFET Temp Cutoff Start:** System decreases power usage when temperature reaches this value (default 80°C)
- **MOSFET Temp Cutoff End:** System stops motor operation when temperature reaches this value (default 100°C)
- **MOTOR Temp Cutoff Start:** System decreases power usage when temperature reaches this value (default 80°C). Motor Temp sensors needed for this feature.
- **MOTOR Temp Cutoff End:** System stops motor operation when temperature reaches this value (default 100°C). Motor Temp sensors needed for this feature.

Please visit www.vesc-project.com/documentation for more Information. **If you are unsure about any setting inform yourself or send us a message to prevent any danger. Start using values on the safe side and check if any part of your electrical system starts to heat up beyond safe limits of operation.**

Warning: When using the motor as a generator (e.g. as a regenerative motor brake), your battery will be charged with the setting found in **Motor Settings >> General >> Current Tab** of VESC-Tool. The **Battery Current Max Regen** value will define the maximum Ampflow pushed towards your battery when the motor is operated as a generator (e.g. during regenerative braking). Make sure your battery can handle the ampflow, as defined in the settings mentioned above. The maximum battery charge currents can be found in the batteries documentation and data sheets. **Never use your motor as a generator when your battery is fully charged**, especially if your battery is vulnerable to catch fire or explode when overcharged. **LITHIUM BATTERIES and other types of Batteries ARE potentially DANGEROUS!**

Depending on your application you may need to include a **Battery Managemant System (BMS)** to safely operate your battery and to give you feedback, when the battery is fully charged. Stop using the motor as a generator until your battery is discharged enough to cope with regenerative braking again. **Never drain more Amps** than your battery and/or motor can cope with (Max rating for continuous Amp flow). Use safe settings for all parameters found in the **Motor Settings >> General >> Current Tab!**

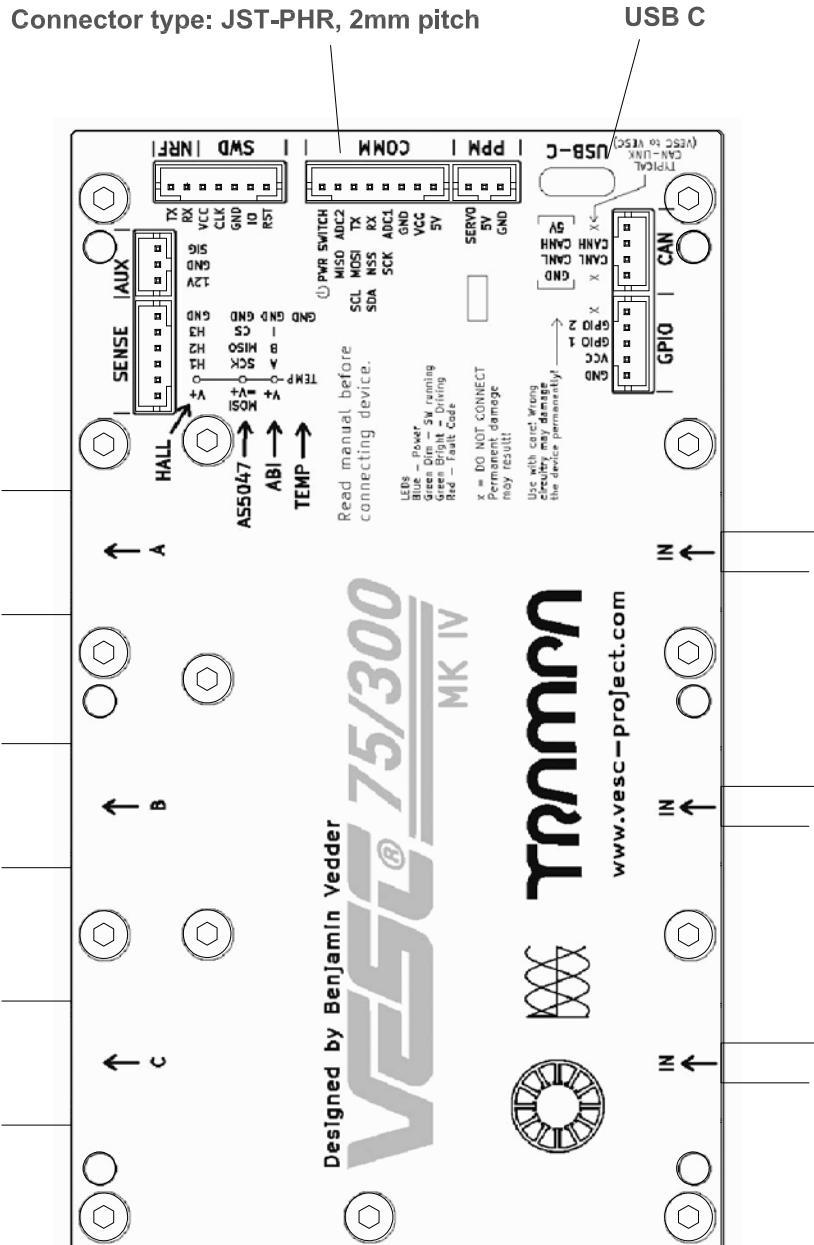

Connectors and Switches:

The VESC controller is equipped with USB, CAN-Bus, PPM, COMM, SWD, NRF and a Sensor port. The following List will give you an idea how to interconnect the VESC controller to other devices.

- **Sensors:** Sensor Port for **ABI, HALL or AS5047P motor position sensors**. Motor sensors allow precise and powerful rotation of the motors rotor from a random (standstill) position or from a defined position A to a defined position B. The sensor voltage will switch according to the detected sensor type. 3.3V or 5V is possible. Did you check the wiring scheme of your sensor cable?
- **SWD:** **Serial Wire Debug** allows to access the STM32 Chip while running your VESC controller: Diagnostics, debugging and real time data + second UART RX/TX
- **COMM :** I2C, UART and ADC Interface to allow communication with other devices, such as Microcontrollers (e.g. Arduino, Raspberry Pi) or using analog input devices (e.g. analog throttle)
- **ON/OFF** Use momentary (**Normally Closed**) switch to wake up device from hibernation.
- **PPM:** Connect input devices using **Pulse-Position Modulation** e.g. a 2.4GHz transceiver for controlling the motors output power and speed (Radio control).
Never connect one receiver to separate VESC devices (Y-PPM). Use opto decouplers!
- **CAN:** CAN BUS for interconnection of VESC devices in an array. E.g. when implementing traction control in a multi drive setup or when powering up multiple motors, using multiple VESC devices (master + slave 1, 2, 3,...). CAN-bus is also a universal bus to link the VESC controller to other devices also featuring CAN-Bus. **Only connect CAN L and CAN H! If connected to the same battery, all devices must be connected to the same battery GND at all times! Never interrupt this connection while the CAN cable is attached! The GND pin and 5V pin of the CAN link should never be connected in an array of controllers!**
- **Motor A,B,C** Connectors for a single three phase wired BLDC Motor (Coil A, B, C). If you know your motor phases, plug in the phases accordingly (Yellow = A, Blue=B, Red=C) to be displayed correctly in the VESC-Tool real time data analysis. DC-Motors use only connections **A** and **C**, B will be left unplugged!
- **USB** USB-Port to connect to a computer for the purpose of configuration, firmware updates and real time data analysis.
- **GPIO** Two **General Purpose** IO pins for programmable use.
- **AUX** 12V Auxiliary supply for external 12V devices. SIG = 12V out, switched via software.

Please visit www.vesc-project.com/documentation for more Information.

The following LED light Codes will be displayed by your VESC controller:

- **BLUE:** VESC controller is powered up
- **GREEN DIM:** SW Running >> Software (Firmware) installed and running
- **Green Bright:** VESC controller is driving the motor.
- **Red:** Fault code, something is wrong! Read out the fault code in VESC-Tool.

Switch wiring options for one or more VESC 75/300 MKVI devices

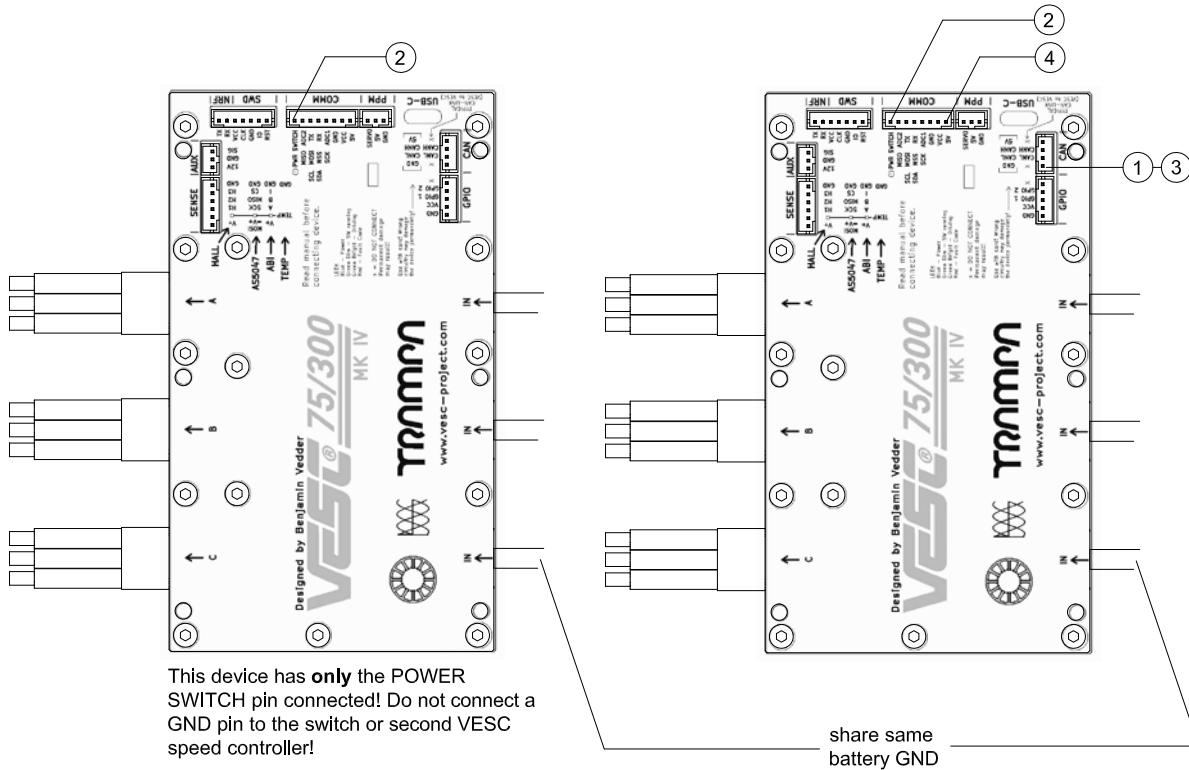

Wiring using a Normally Closed (NC) switch or bridge cable

<p>OPTION 1: Using a LED (5V) illuminated power switch</p>	<ul style="list-style-type: none"> -manual power off/on -roll to start -LED indicates state -auto power off
<p>OPTION 2: Using a non illuminated power switch</p>	<ul style="list-style-type: none"> -manual power off/on -roll to start -auto power off
<p>OPTION 3: Use a separate soft start power switch. Do not connect any wires</p>	<ul style="list-style-type: none"> -no auto power off -no use of integrated switch

Ground loops will damage your devices. Follow the guidelines below to prevent loops.

Multiple VESC controllers connected to one receiver or micro controller via PPM, UART, I²C or SPI. Receiver or micro controller has its own power supply.

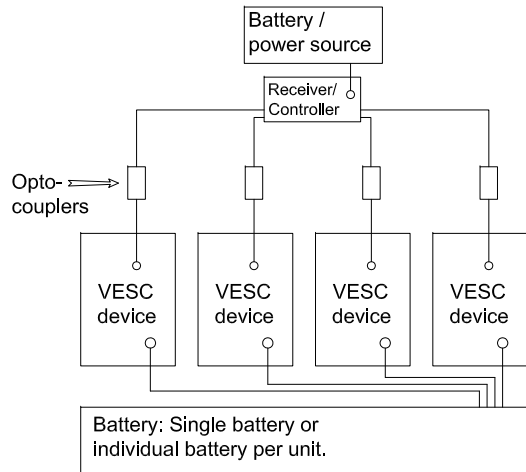

Multiple VESC controllers connected to one receiver or micro controller via PPM, UART, I²C or SPI. Receiver or micro controller is powered by one VESC device.

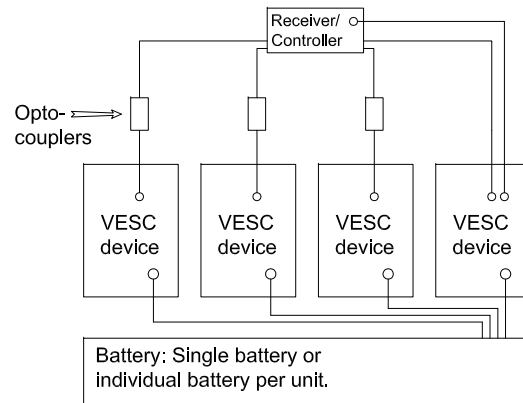

Multiple VESC controllers connected to one receiver or micro controller via PPM, UART, I²C or SPI. All devices are powered by the same battery.

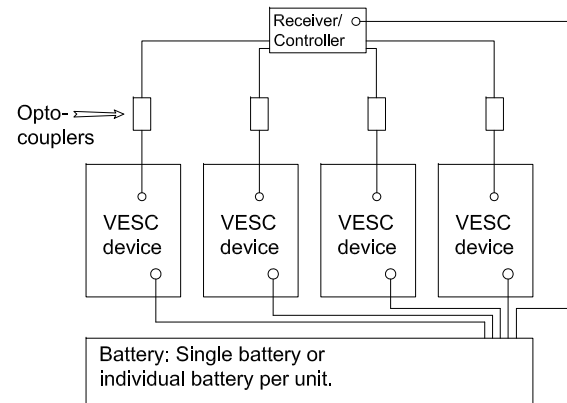

Ground loop via grid! Run computer from battery or use USB isolator.

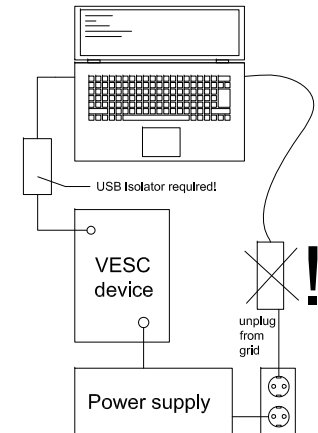

Multiple VESC controllers connected to one receiver or micro controller via PPM, UART, I²C or SPI. Receiver or micro controller is attached to other devices.

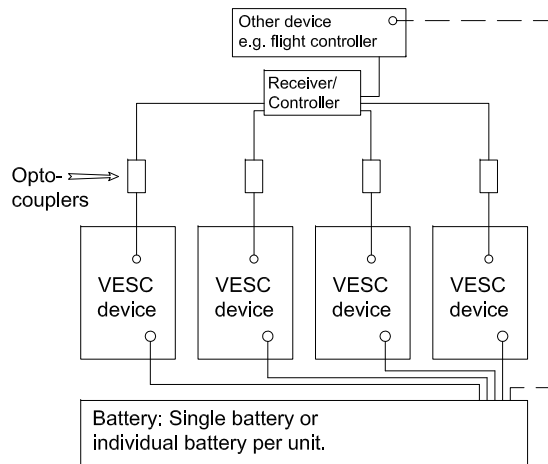

Multiple VESC controllers connected to one receiver or micro controller via CAN. Receiver or controller can be powered from any source. Only connect CAN H and CAN L.

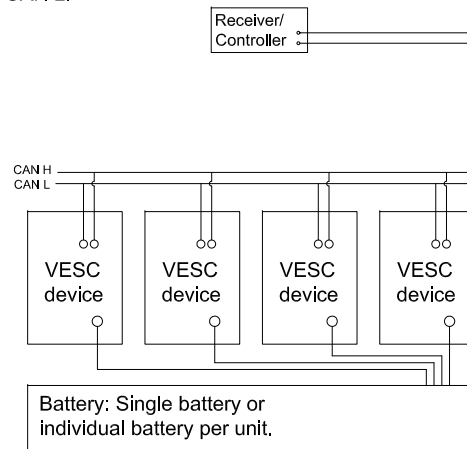

Never share any connections, other than CAN H and CAN L with other VESC devices. This will typically create a ground loop. Ground loops will damage your controllers. Only the battery ground may be shared. Use optocouplers instead.

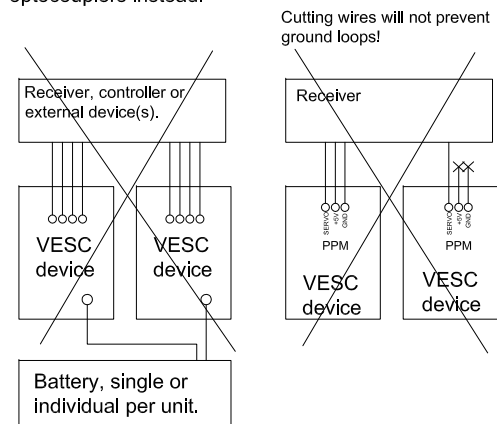

Typical ground loop free setup. Controller/Receiver powered by VESC device. Further devices linked via CAN.

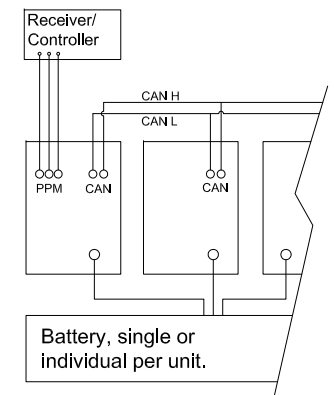

Technical Data Sheet

- Voltage: 6V – 75V (Safe for 3S to 16S LiPo/Lilon). Voltage spikes may not exceed 75V!
- Current: Continuous 300A, Burst 450A. Values depend on the temperature, switching frequency and cooling of the device!
- 5V 1A output for external electronics
- 12V 0,5 A output for external electronics
- 3.3V 0,5A output for external electronics
- Modes: DC, BLDC, FOC (sinusoidal)
- Supported sensors: ABI, HALL, AS5047, MT6816

Features

- Accurate current and voltage measurement on all phases
- Adjustable Current and voltage sensors
- Works reliably with nearly any motor and low inductance motors
- Regenerative braking
- Sensored or sensorless operation + hybrid mode
- Advanced Sensorless Startup, full torque from 0 RPM for salient motor designs (needs motor temps sensor).
- Configurable RPM-, current-, voltage- and power limits
- Input source: PPM, Analog, NRF (BLE 4.1), CAN, UART, SPI
- Communication: USB, CAN, UART, I²C, SPI, GPIO, Analogue
- Adjustable throttle curve and ramping for all input sources
- Seamless 4-quadrant operation
- Motor revolution, amp hour, watt hour counting
- Transmission and wheel diameter configurable
- Therefore accurate calculation of speed and consumption
- Display of speed, power, duty cycle, amp flow, estimated range and battery status on VESC-Tool App
- BLE / WiFi wireless connection via external dongle possible.
- Real time data analysis and read out via communication ports
- Hibernation via momentary switch (**Normally Closed**)
- Adjustable protection against:
 - Low input voltage
 - High input voltage
 - High motor current
 - High input current
 - High regenerative braking current (separate limits for the motor and the input)
 - High RPM (separate limits for each direction).
 - Over tempertaure (MOSFET and motor)



Some things to take into account when building your system:

Building electrical systems and driving motors requires patience and also a certain amount of experience. We want to help you to avoid certain mistakes which could easily cause damage to your device, or interlinked devices and the consequences of such failures. Some of the most common pitfalls are:

1. Ground Loops
2. No pre-charge (power source to VESC controller)
4. Disconnection from the battery during operation
5. Usage of a lab power supply
6. Wrong motor parameters & difficult to drive motors

This list considers only the most common pitfalls and is not a complete list of system inadequacies with the potential to cause trouble and damage.

Ground loops

GND Loops are loops that link a secondary ground net to the existing ground net. The most simple example is a direct or indirect connection from any VESC ground pin (e.g., gnd on COMM port) back to the ground on the power source. Typically that happens when a secondary micro controller is used to control the VESC device. This micro controller is powered by the shared battery or its own battery, but it has its own voltage regulators and ground net. It should therefore be galvanically isolated from the VESC motor controller. The same applies to two VESC motor controllers sharing one input device. The two motor controllers logic stages need to be galvanically isolated from another. Typical mistake: use one receiver to control two VESC motor controllers via PPM/PWM. A commonly shared ground (logic to logic stage) is not possible and galvanic isolation needs to be built into the system.

OK: Use Arduino to control VESC 75/300, if powered by the VESC 5V rail.

NOT OK: Connect to said Arduino with a standard USB cable. Arduino is now getting power from VESC side and computer! Gnd net from VESC and computer are now interconnected.

Resolve: Use USB cable with galvanic isolation or decouple Arduino and VESC-controller via galvanic isolation board (preferred)

Best practice: Use CAN-Bus as much as possible to interlink devices. Use galvanic isolation boards for interconnection of input devices like micro controllers.

Pre-Charge Switch

The VESC 75/300 has quite a bit of built in capacitance! If it is connected to the power source without sufficient pre-charge circuitry, high inrush current will be the result. This can create massive sparks at the connectors and also voltage spikes above the voltage rating of the device. **Permanent damage may be the result!** The VESC 75/300 needs to be powered via a pre-charge switch, limiting the initial inrush current until the capacitors are fully charged. Typically the initial contact should be made via a 10Ohm resistor with enough power dissipation capability to survive thousands of power cycles. The power rating of the resistor depends on the total capacitance in the entire electrical system. After the pre-charge phase, full contact can be established. Make sure that after a switching cycle into the off state sufficient pre-charge is applied again. Some pre-charge switches tend to behave like a loose contact, quickly opening and closing during high power drain. This behaviour will very likely damage the VESC motor controller.

Disconnection from battery

A VESC motor controller works in harmony with a battery. You basically create an oscillating system that comprises of a motor, a motor controller and a battery. The flow of energy in between all components should not be interrupted during operation without taking adequate measures to prevent damages. If the battery is disconnected while driving the motor or if the current flow towards the battery is limited during operation, the system can't be seen as being in a healthy state. This can result in very high voltage spikes, exceeding the rating of the VESC motor controller and therefore damaging components on the circuit board.

A power switch or BMS with built in power switch should therefore never cut off the battery from the motor controller without sending adequate commands to the VESC controller first, bringing it into a safe state and stop driving the motor or take braking commands (regeneration / recuperation). Some BMS systems measure the current flow from the battery and they cut off the battery from the VESC-controller when current spikes are registered. Please consider that driving a motor with 300A may create short spikes at way higher rate (e.g. 700A). A switch must be programmed to not take action in such an event without putting the VESC controller into a safe state first. Ideally the BMS / switch is CAN interlinked with the VESC 75/300 and programmed to prevent damages on the motor controller side. If the switch and VESC 75/300 are not interlinked with an adequate communication protocol, the switch should stay in the on state at all times the motor is driven (fwd, reverse, regen).

Usage of a lab power supply

The VESC 75/300 is not designed to work in conjunction with a power supply that is connected to the mains. We always need a component to dump energy into! Typically this is our battery.

Wrong motor parameters & difficult to drive motors

The VESC software incorporates algorithms allowing the detection of most motors that are likely to be attached to the VESC 75/300. However, not every motor is easy to detect with a standardised detection routine. Such motors either do not run stable after detection or they create massive current/voltage spikes, potentially damaging the motor controller. A good approach is starting with lower voltage experiments and lower *Motor Current Max* values and lower *Absolute Maximum Currents* values, closing the gap in between those two values. Example: 100A Motor Current Max, 180A Absolute Maximum Current.

If a motor creates high current spikes during operation, it is likely to run on non optimal motor detection parameters. Another reason for such spikes could be stator saturation, causing system instabilities and high current events. For example such behaviours could occur when driving high pole count outrunner motors designed for multi rotor drones.

Work your way up with care, monitor the operation and adjust parameters before trying to reach higher output power levels. Use VESC-Tools RT-Data analysis to monitor current spikes and other non expected behaviour. If you can't resolve the matter, try to obtain motor parameters from the manufacturer and compare the values to the detection results. Get back to us when you can't resolve your matter and post your issue on <https://vesc-project.com/forum>. It is likely that someone is using the same or similar motor and has good advice for you. And once the issue is resolved we can make the information available for other.

If your system is likely to create high current spikes (e.g. via high inertia), consider to use lower current values, longer ramping times or a bigger motor controller.

It is wise to operate the controller with the most optimal motor parameters and with a good portion of head room. Pushing a controller to much towards its edge might damage it over time or at a certain event.

This device is manufactured to meet the **RoHS2** (2011/65/EU) regulations.



Instructions for disposal of WEEE by users in the European Union

This product must not be disposed of with other waste. Instead, it is the user's responsibility to dispose of their waste equipment by handing it over to a designated collection point for the recycling of waste electrical and electronic equipment. The separate collection and recycling of your waste equipment at the time of disposal will help to conserve natural resources and ensure that it is recycled in a manner that protects human health and the environment. For more information about where you can drop off your waste equipment for recycling, please contact your local city office, your household waste disposal service or where you purchased the product.

TRAMPA BOARDS LTD 2002 - 2016
 Company Registration UK 4653504
 Registered Business Address
 Unit 16, Centre Court,
 33 Little Tennis Street,
 Colwick, Nottingham,
 NG2 4EL, United Kingdom

L'objet de la déclaration est en conformité avec la directive **RoHS 2** (2011/65/EU).



Élimination dans l'Union Européenne

Ce produit ne doit pas être éliminé avec les ordures ménagères. Il est de la responsabilité de l'utilisateur de remettre le produit à un point de collecte officiel des déchets d'équipements électriques. Cette procédure permet de garantir le respect de l'environnement et l'absence de sollicitation excessive des ressources naturelles. Elle protège de plus le bien-être de la communauté humaine. Pour plus d'informations quant aux lieux d'éliminations des déchets d'équipements électriques, vous pouvez contacter votre mairie ou le service local de traitement des ordures ménagères.

TRAMPA BOARDS LTD 2002 - 2016
 Company Registration UK 4653504
 Registered Business Address
 Unit 16, Centre Court,
 33 Little Tennis Street,
 Colwick, Nottingham,
 NG2 4EL, United Kingdom

Diese Gerät wurde gemäß der Richtlinie **RoHS2** (2011/65/EU) hergestellt.



Anweisungen zur Entsorgung von Elektro—und Elektronik-Altgeräten für Benutzer in der Europäischen Union

Dieses Produkt darf nicht zusammen mit anderem Abfall entsorgt werden. Stattdessen ist der Benutzer dafür verantwortlich, unbrauchbare Geräte durch Abgabe bei einer speziellen Sammelstelle für das Recycling von unbrauchbaren elektrischen und elektronischen Geräten zu entsorgen. Die separate Sammlung und das Recycling von unbrauchbaren Geräten zum Zeitpunkt der Entsorgung hilft, natürliche Ressourcen zu bewahren und sicherzustellen, dass Geräte auf eine Weise wiederverwertet werden, bei der die menschliche Gesundheit und die Umwelt geschützt werden. Weitere Informationen dazu, wo sie unbrauchbare Geräte zum Recycling abgeben können, erhalten Sie bei lokalen Ämtern, bei der Müllabfuhr für Haushaltsmüll sowie dort, wo sie das Produkt gekauft haben.

TRAMPA BOARDS LTD 2002 - 2016
 Company Registration UK 4653504
 Registered Business Address
 Unit 16, Centre Court,
 33 Little Tennis Street,
 Colwick, Nottingham,
 NG2 4EL, United Kingdom